

# INSTALLATION INSTRUCTIONS

## **Xtender Pro™** HEAVY DUTY **TRUCK BED EXTENDER** FOR CONSTRUCTION AND RECREATIONAL APPLICATIONS



© 2023 Paragon Pro Manufacturing Solutions All Rights Reserved.

For proper installation in best possible fit please read all instructions before you begin for technical assistance or to obtain missing parts, Please call customer service at 1-800-448-0822  
XtenderPro.com

# INSTALLATION INSTRUCTIONS

## **Xtender Pro™** HEAVY DUTY **TRUCK BED EXTENDER** FOR CONSTRUCTION AND RECREATIONAL APPLICATIONS

For proper installation and best possible fit, please read all instructions before you begin. For technical assistance or to obtain missing parts, please call customer service at 1-800-448-0822



### IMPORTANT SAFETY INFORMATION

- Check local and state laws before using Xtender Pro™
- Do not use Xtender Pro™ if damaged
- Do not use Xtender Pro™ if any parts are missing
- Use during daylight hours only
- Use only with class four or higher hitches
- Do not exceed cargo load rating of your vehicle
- Do not exceed rating of your receiver
- Do not cut drill, weld or modify Xtender Pro™
- Attach safety flag to end of load
- Install all pins securely
- Do not use Xtender Pro™ when vehicle is not loaded
- Do not use Xtender Pro™ with loads extending more than 6 feet beyond the back edge of dropped tailgate, and no more than 3 feet beyond Xtender Pro™ T-bar
- Set elevation of T-bar to match the level of truck bed and match and roof level for upright mode
- Loads must be placed against the front of the truck bed center.
- Load in the middle of the truck bed and in the middle of the Xtender Pro™, then tie the load down so that it will not bounce or slide in any direction

### CONTENTS

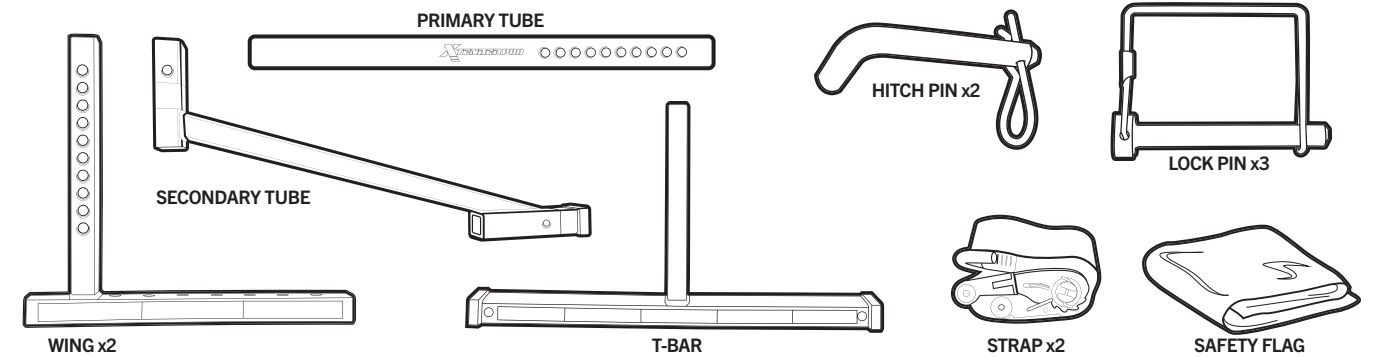

### EXTENDED MODE

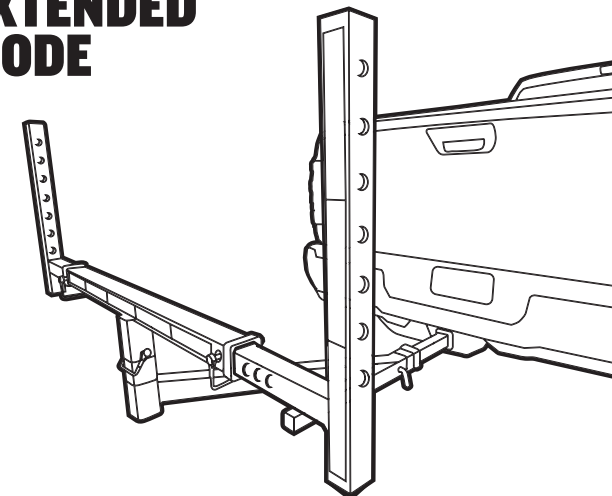

### 1A

Insert primary tube into receiver. Insert hitch pin.

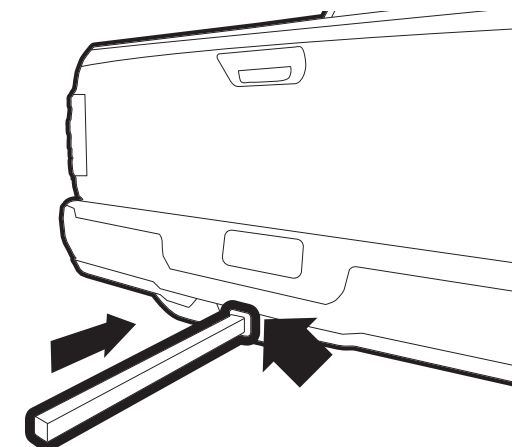

## INSTALLATION INSTRUCTIONS

**2A** Insert secondary tube over primary tube and install hitch pin.

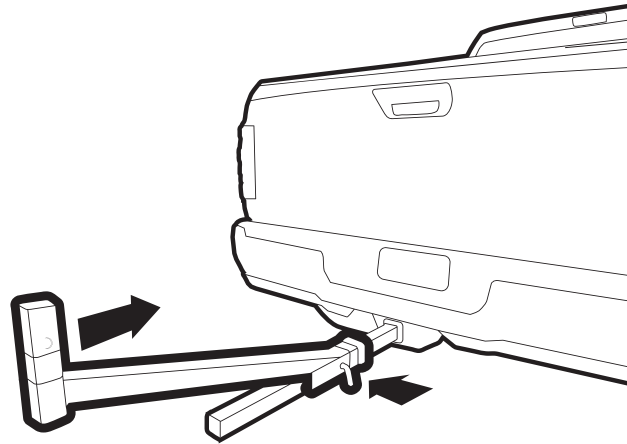

**3A** Lower tailgate of vehicle and adjust height of T-bar. Install T-bar into secondary tube w/ reflector facing outward. Secure with lock pin.

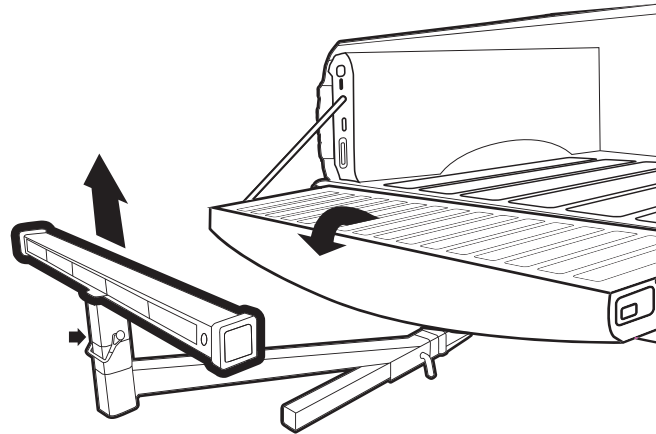

**4A** Install wings onto T-bar. Secure in place with (2) lock pins.

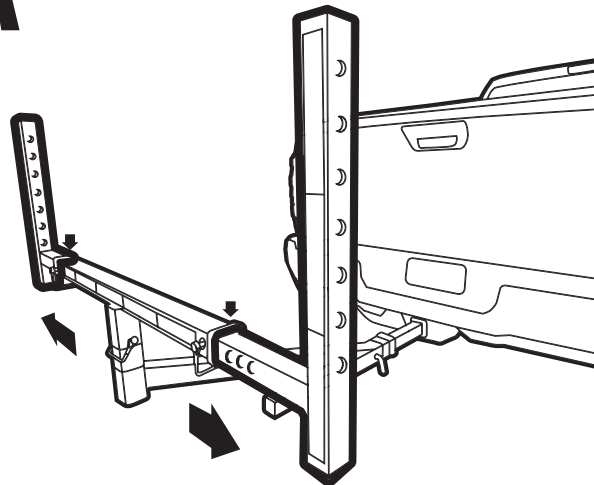

**UPRIGHT MODE**

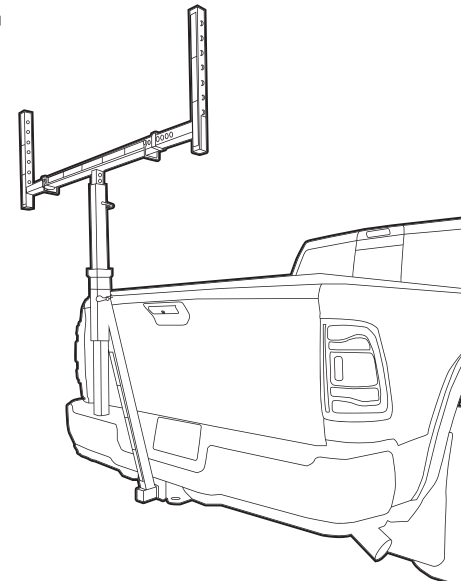

ATTACH SAFETY FLAG TO END OF LOAD BEFORE TRANSPORT.

**1B** Insert secondary tube and install hitch pin.

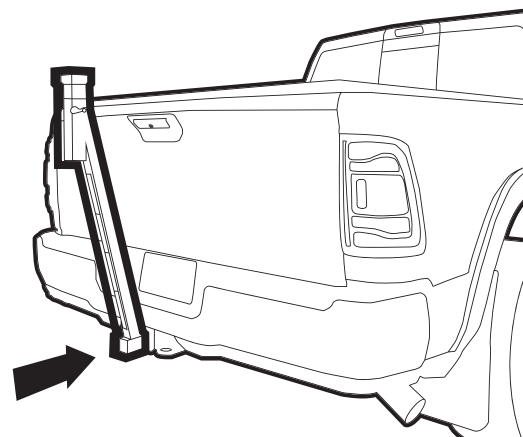

**2B** Insert primary tube through secondary tube and install hitch pin.

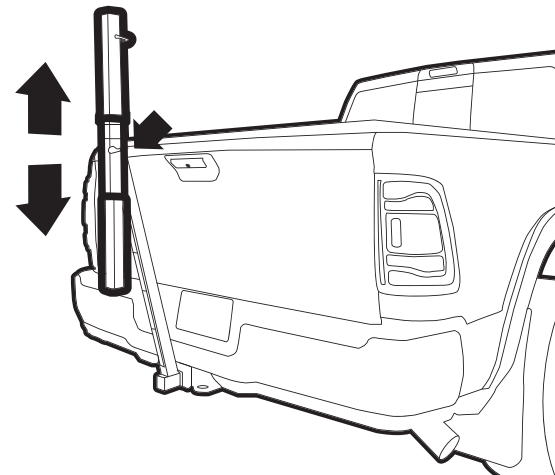

## INSTALLATION INSTRUCTIONS

**3B** Install T-bar into primary tube w/ reflector facing outward. Insert lock pin to secure in place.

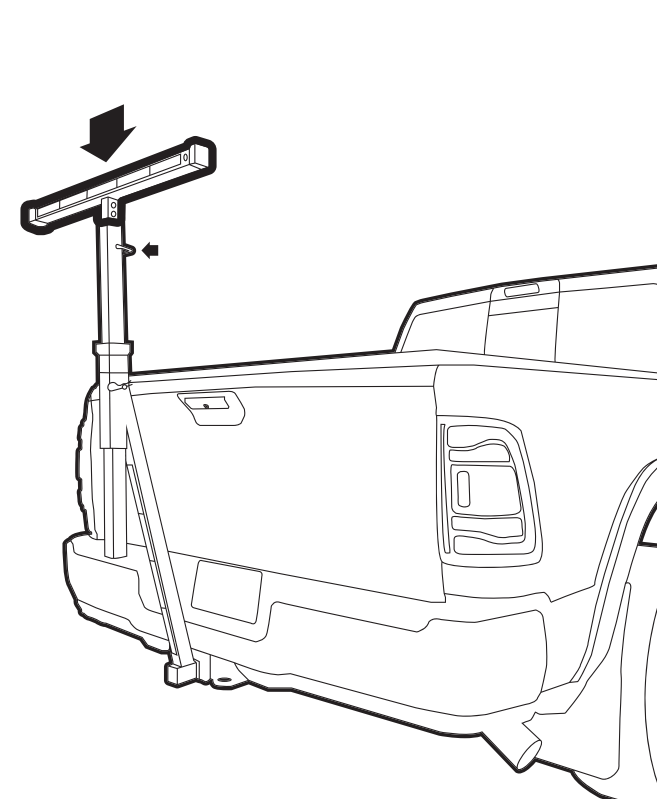

**4B** Install wings onto T-bar. Secure in place with (2) lock pins.

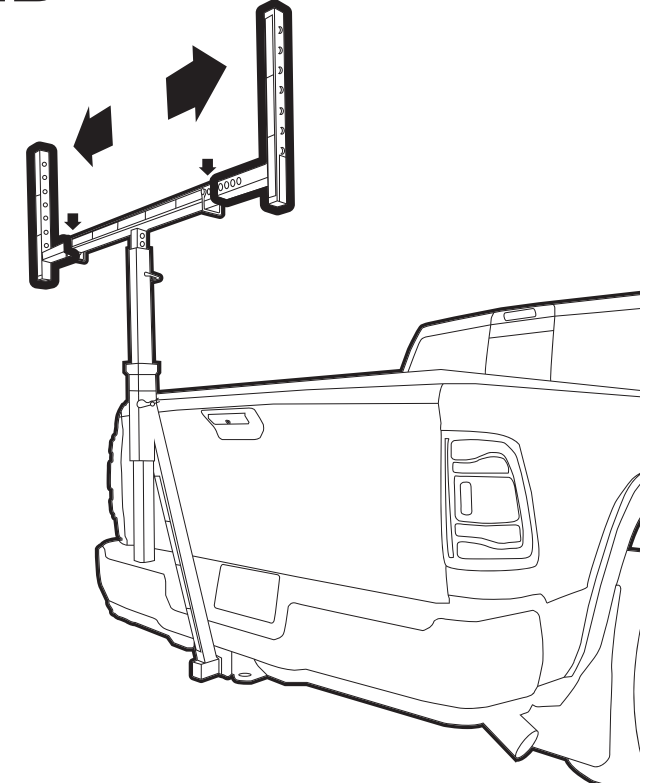

ATTACH SAFETY FLAG TO END OF LOAD BEFORE TRANSPORT.

Xtender Pro™ is a universal load hauler that extends your truck bed or overhead roof rack, enabling you to carry longer loads more safely and securely. From lumber and plumbing to kayaks and canoes, this heavy-duty rack is built to handle items with ease.

### ! WARNING !

DO NOT BLOCK TAIL LIGHTS, BRAKE LIGHTS, OR TURN SIGNALS. ALWAYS INSTALL T-BAR WITH REFLECTIVE TAPE FACING AWAY FROM VEHICLE. DO NOT USE AFTER DARK OR IN LOW LIGHT CONDITIONS.

BEFORE EACH USE, A VISUAL INSPECTION MUST BE PERFORMED TO ENSURE PRODUCT IS FREE OF DEFECTS OR DAMAGE THAT MAY LEAD TO PROPERTY DAMAGE OR INJURY. ANY DAMAGED PARTS MUST BE REPLACED PRIOR TO OPERATION. ONLY ORIGINAL EQUIPMENT MANUFACTURER-SUPPLIED PARTS TO BE USED IN OPERATION AND TRANSPORT OF THE XTENDER PRO™.

For proper installation and best possible fit, please read all instructions before you begin. For technical assistance or to obtain missing parts, please call customer service at 1-800-448-0822